

GNP - 2

Automatic transfer switch controller

The completely automatic transfer switch monitors incoming voltage from the 3 Phase utility lines, around the clock. When utility power is interrupted, the automatic transfer switch immediately senses the problem and signals the generator to start. Once the generator is running at proper speed, the automatic transfer switch safely shuts off the utility line and simultaneously opens the generator power line from the generator. Within seconds, your generator system begins supplying electricity to the critical emergency circuits of your home or business. The transfer switch continues to monitor the utility line conditions. When the automatic transfer switch senses the utility line voltage has returned at a steady state, it re-transfers the electrical load back to the utility line and resumes monitoring for subsequent utility loss. The entire system stands ready for the next power outage.

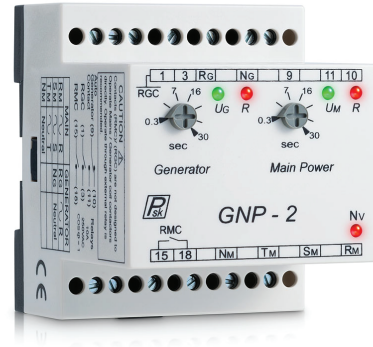

Features

- Supervision three-phase supply lines.
- Phase sequence and total loss of one or more phase.
- Loss of neutral line.
- User controlled delayed transition.
- 3% Hysteresis insure smooth transfer.
- Device protected against voltage harmonics

Operation Sequence Description

Correct main supply

Operation	Indication	Explanation
1 Applied 3 Phase main supply	LED (UM) on	indicates: 3 phase main connection on
2 Delay time	LED (NV) on (0 – 30sec)	indicates: Neutral connection on can be adjusted from the front panel
3 At the end of delay interval	Main relay RMC energize	contacts (15) & (18) closed
	Mains LED (R) on	indicates: mains contactor energizes
	Relay Contacts (11)&(9) closed	indicates: generator auto activation is disconnected

Mains Power failure

Operation	Indication	Explanation
1 Main power failure	Contacts (10) & (9) closed	commands generator on
	LED indicator (UG) on	indicates: GNP-2 supplies from generator
	LED indicator (NV) off	indicates: main Supply voltage failure
	LED indicator (UM) off	indicates: main Supply voltage failure
2 Delay timer At the end of delay interval	(0 – 30sec)	can be adjusted from the front panel
	relay RGC energize	Contacts (1) & (3) closed
	LED indicator (R) generator on	indicates "GEN" contactor energizes

Mains Voltage Restored

Operation	Indication	Explanation
1 Restored 3 phase main	LED indicator (UM) on	indicates: 3 phase main connection on
2 Delay timer	LED indicator (NV) on (0 – 30sec)	indicates: Neutral connection on can be adjusted from the front panel
3 At the end of delay interval	Relay (RGC) de-energize	Generator main contactor (CG) de-energize LED indicator (R) generator off LED indicator (UG) off
	4 After additional 1sec internal delay	Main relay RMC energize Mains LED (R) on Relay Contacts (11)&(9) closed

Indicator lights and Contacts

	LED Indication	Led Color	Description
Main	UM	Green	Gnp- 2 Receive 3 phase supply from mains
	R	Red	Contacts (15) & (18) closed
	NV	Red	Neutral connection ok
Generator	UG	Green	Input voltage generator operates
	R	Red	Relay (RGC) Energize contacts (1) & (3) closed
Contacts	(11) (10) (9)		Contact outputs for generator Operation
	(NG) (RG)		Generator voltage input supply
	(NM) (TM) (SM) (RM)		3 phase voltage supply to Mains
	(RMC)		N/O mains switch relay
	(RGC)		N/O generator switch relay
Timers	Mains timer		Delay on make (0-30sec) adjustable from the front panel
	Generator timer		Delay on make (0-30sec) adjustable from the front panel



GNP - 2

Automatic transfer switch controller

Technical Data

Operational Voltage:	3 x 208VAC 50/60Hz
Relays:	1 form C (SPDT)
Switching capacity:	10A /240V COS $\phi = 1$
Rated voltage:	250VAC
Contact rating (resistive load):	10A 250VAC, 6A 30VDC
Max switching Power / current:	2000W 12A
Mechanical life:	1 x 10 ⁶ ops (at rated load)
Electrical life:	1 : 200,000 ops
Operating Temp:	-20°C+ 55°C
Storage temp:	-25°C+70°C
Transport temperature:	-25°C....+70°C
Relative humidity:	15%...85%
Case material:	Self-extinguishing plastic housing UL V0 acc IEC 529
Mounted:	on DIN-rail TS 35 according to EN 50022
Mounting position:	Horizontally
Protection class open air	IP20
Terminal certification:	IEC 60947-7-1, IEC 60998-1
Certification & compliance acc to :	EN 61010- 1:2010, IEC 61010-1:2010
Terminal Capacity:	1x4mm ² without multicore cable end 1x0.5 to 2.5mm ² with/without multicore cable end
Wight:	171 gram

Schematic connection

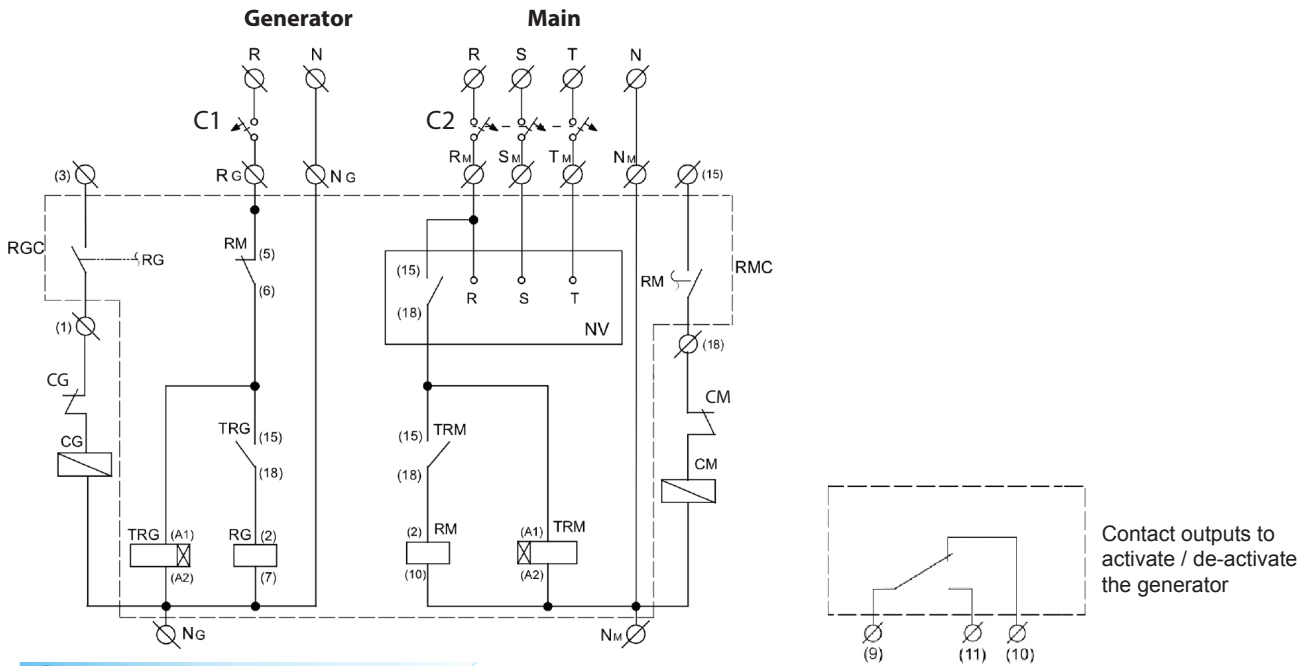

Dimensions

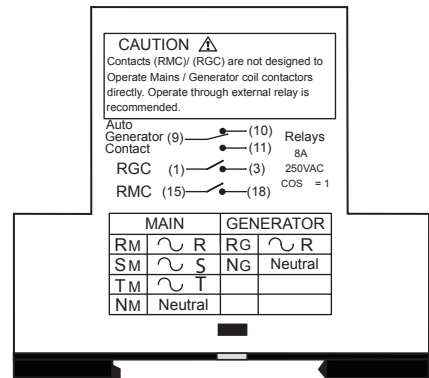
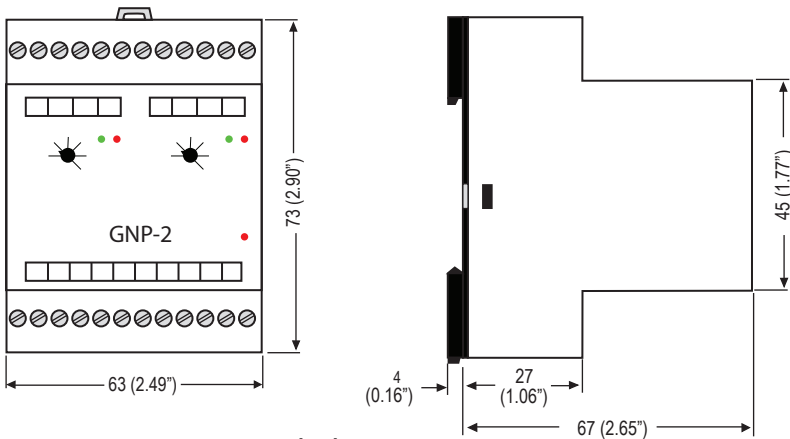

Protection Recommended:

- C1 1 Pole C curve Circuit Breaker 4A
- C2 3 Pole C curve Circuit Breaker 4A



Installation Guide

Mounting

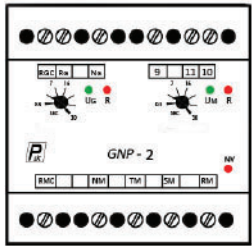

60 mm min

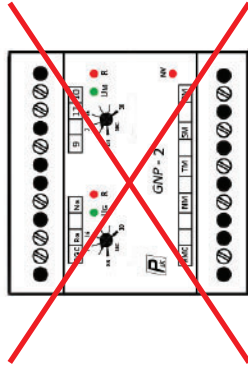
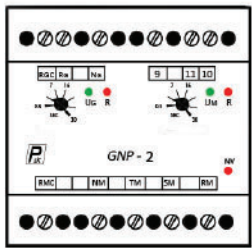

70 mm min

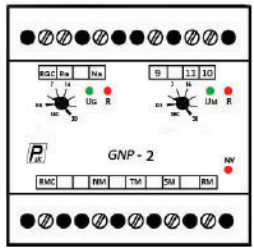

70 mm min



Wiring					
75°C Wire					
L1 - T1	[mm ²] 0.05 ÷ 4	[mm ²] 0.05 ÷ 4	N.A.		 M3 0.5Nm
N, 1, 2, 3 W, X, (+) (-)	[mm ²] 0.05 - 4	[mm ²] 0.05 - 4	N.A.	N.A.	M3 0.5Nm Max

important: When using electric or pneumatic tools for screw terminals observe max. torque limits

Precautions For Installation and Safe Use

Failure to follow those instructions will result in death or serious injury.

- Disconnect all power before working on equipment.
- Do not try to clean the device with solvent or the like. Only clean the device with a dried cloth.
- Verify correct terminal connections when wiring.
- To connect the unit, use appropriate insulated 120VAC cord.
- Electrical equipment should be serviced only by your competent seller.
- Mounted on DIN - rail TS 35 according to EN 50022.
- Product intended for installation in electrical cabinets or IC boxes.

No responsibility is assured by the manufacturer or any of its subsidiaries for any consequences arising out of the use of this material.



WARNING

The systems type GNP1/GNP2/GNP-SP are not approved for use in resuscitation facilities, or individual analysis facilities or medical facilities that support human life or stabilizers, such as: emergency rooms, ambulatory rooms, resuscitation rooms, etc. The buyer agrees to notify PSK Controllers Ltd presentation on the use of the products listed in one of the facilities mentioned above. To make it clear, only PSK Controllers Ltd, have the right to decide and determine which product is suitable for use under the requirements uses. If the equipment is used in a manner not specified by the manufacture, the protection provide by the equipment may be impaired.

*It is recommended to install a bypass switch for an emergency event.

